

# Product Data Sheet



## 133X272 CH

Replace "X" with 1, 2 or 3 for number of poles

510 Amps, 600 Volts (AC/DC)

See tables below for Flexible stranded and multiple wire approvals.

### Wire Range:

Line side: 3/8 – 16 X 1 3/16

Load Side: (12) #4 – #14 AWG



### Electrical Ratings:

- 510A Copper wire, 510A Aluminum wire (Based on NEC Table 310-16, 75°C columns)
- 600 Volts AC/DC (UL 1059 Class C, User Group - General Industrial)
- Factory and Field Wiring

### Mechanical Ratings:

- Maximum insulator base and cover temperature: 125 °C (257 °F) UL RTI
- Storage and transportation temperature range: -35 °C to 110 °C (-31 °F to 230 °F)
- Flammability rating of insulator base and cover: UL 94 V-0
- \* Use outside these ratings needs to be judged in the end-use application.

### Materials:

- Connector: High conductivity aluminum, tin plated
- Insulator base: glass filled polycarbonate (thermoplastic)
- Terminal set screws: Steel, nickel plated
- Studs: Brass, tin plated
- Nuts: Brass, nickel plated
- Connector mounting screws: Steel, zinc plated
- Hinged cover: glass filled polycarbonate (thermoplastic)

### Agency Approvals:

- UL Recognized, UL 1059 Terminal Block Standard, File No. XCFR2.E62806
- CSA Certified, CSA C22.2 No. 158, File No. LR19766 (Wire Classes B & C only)
- CE compliant to IEC 60947-7-1
- RoHS Compliant

## Wire Approvals:

### Line Side Torque Approvals:

3/8 – 16 Stud: 192 in. lbs

### Load Side Wire Approvals:

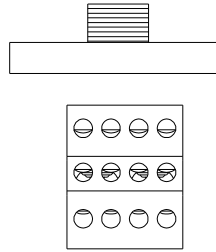

		Copper Wire Stranding Classes - Number of Strands						
Wire Size	Torque	Solid	Class B	Class C	Class G	Class H	Class I	Class K
4 AWG	35 in. lbs		7	19				
6	35 in. lbs		7	19	~ 49	~ 133	~ 63	~ 266
8	35 in. lbs		7	19	~ 49	~ 133	~ 41	~ 168
10	35 in. lbs	1	(1-2)* 7	(1-2)* 19			(1-2)* ~ 27	(1-2)* ~ 104
12	35 in. lbs	1	(1-4)* 7	(1-4)* 19			(1-2)* ~ 19	(1-2)* ~ 65
14	35 in. lbs	1	(1-4)* 7	(1-4)* 19			(1-2)* ~ 19	(1-2)* ~ 41

~Quantity of strands for Classes G, H, I, K may vary by manufacturer.

\* Multiple conductor approvals (copper wire only)

Aluminum Wire Range: #4 – #8 AWG

- Wire strip length, load side taps: top – 1/2”, middle – 11/16”, bottom – 13/16”
- Hex key required : 1/8”
- Panel mountable: #10 fastener, torque to 25-30 in. lbs.

### Accessories:

- Marker Strips. Printing available. Consult factory.

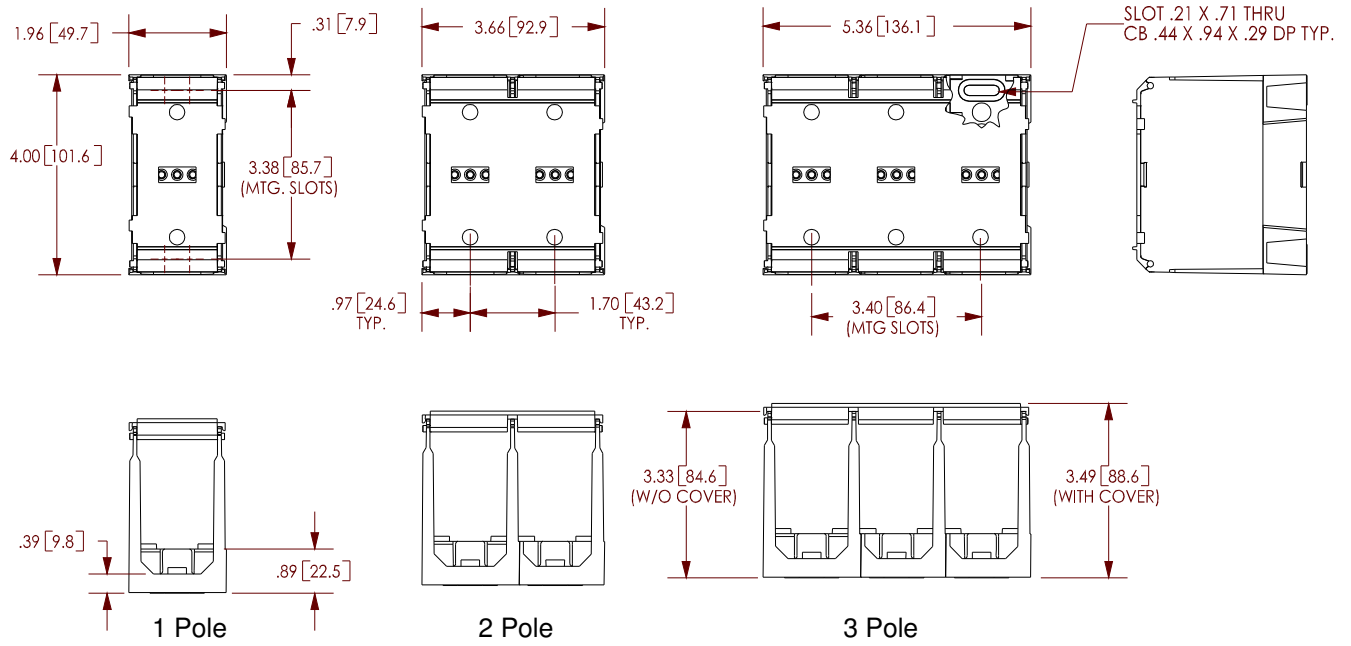

[WWW.MARATHONSP.COM](http://WWW.MARATHONSP.COM)  
1-419-352-8441

PDS 0127 REV A 9/25/07