

Product Data Sheet



133X588

Replace "X" with 1, 2 or 3 for number of poles

Distribution Power Block
420 Amps, 600 Volts (AC/DC)



Wire Range:

Line side: (1) 600kcmil - #2 AWG

Load Side: (3) 1/0 - #14 AWG and (6) #2 - 14

See tables below for SCCR wire ranges, flexible stranded and multiple wire approvals.

Electrical Ratings:

- 420A copper wire, 340A aluminum wire (Based on NEC Table 310-16, 75°C columns)
- 600 Volts AC/DC (UL 1059 Class C, User Group - General Industrial)
- Factory and Field Wiring

Short Circuit Current Ratings (Copper wire only):

Suitable (kcmil/AWG)		Overcurrent Protection Fuse Required Class/Max Amp Rating						SCCR, RMS SYM Amps	Volts Max
Line	Load	J	T	RK1	RK5	G	CC		
600 - 3/0	1/0 - 8	600	600	400	200	60	30	100,000	600
2/0 - 2	2 - 14	200	200	200	100	60	30	100,000	600

Mechanical Ratings:

- Maximum insulator base temperature: 125°C (257°F) UL RTI
- Storage and transportation temperature range: -35°C to 110°C (-31°F to 230°F)
- Flammability rating of insulator base: UL 94 V-0
- * Use outside these ratings needs to be judged in the end-use application.

Materials:

- Connector: High conductivity aluminum, tin plated
- Insulator base: glass filled polycarbonate (thermoplastic)
- Terminal set screws: Aluminum, tin plated, Steel, zinc plated and Steel, nickel plated
- Connector mounting screws: Steel, zinc plated

Agency Approvals:

- UL Recognized, UL 1059 Terminal Block Standard, File No. XCFR2.E62806
- CSA Certified, CSA C22.2 No. 158, File No. LR19766 (Wire Classes B & C only)
- CE compliant to IEC 60947-7-1
- RoHS Compliant

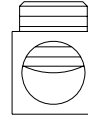

Wire Approvals:

Line Side Wire Approvals:

		Copper Wire Stranding Classes - Number of Strands						
Wire Size	Torque	Solid	Class B	Class C	Class G	Class H	Class I	Class K
600 kcmil	375 in. lbs		37	61				
500	375 in. lbs		37	61				
400	375 in. lbs		37	61	~ 259	~ 427	~ 980	~ 3990
350	375 in. lbs		37	61	~ 259	~ 427	~ 882	~ 3458
300	375 in. lbs		37	61	~ 259	~ 427	~ 735	~ 2989
250	375 in. lbs		37	61	~ 259	~ 427	~ 637	~ 2499
4/0	375 in. lbs		19	37	~ 133	~ 259	~ 532	~ 2107
3/0	375 in. lbs		19	37	~ 133	~ 259	~ 418	~ 1666
2/0	375 in. lbs		19	37	~ 133	~ 259	~ 342	~ 1323
1/0	375 in. lbs		19	37	~ 133	~ 259	~ 266	~ 1064
1	375 in. lbs		19	37	~ 133	~ 259	~ 210	~ 836
2	375 in. lbs		7	19	~ 49	~ 133	~ 161	~ 665

Aluminum stranded wire range: 600kcmil – #2 AWG

~Quantity of strands for Classes G, H, I, K may vary by manufacturer.

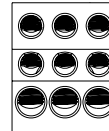

Load Side Wire Approvals:

		Copper Wire Stranding Classes - Number of Strands						
Wire Size	Torque	Solid	Class B	Class C	Class G	Class H	Class I	Class K
1/0 AWG	120 in. lbs		19	37				
1	120 in. lbs		19	37	~ 133	~ 259	~ 210	
2	60 in. lbs		7	19	~ 49	~ 133	~ 161	~ 665
4	60 in. lbs		7	19	~ 49	~ 133	~ 105	~ 420
6	60 in. lbs		7	19	~ 49	~ 133	~ 63	~ 266
8	35 in. lbs		7	19	~ 49	~ 133	~ 41	~ 168
10	35 in. lbs	1	7	19			~ 27	~ 104
12	35 in. lbs	1	7	19			~ 19	~ 65
14	35 in. lbs	1	7	19			~ 19	~ 41

		Copper Wire Stranding Classes - Number of Strands						
Wire Size	Torque	Solid	Class B	Class C	Class G	Class H	Class I	Class K
2 AWG	50 in. lbs		7	19				
4	45 in. lbs		7	19	~ 49	~ 133	~ 105	~ 420
6	45 in. lbs		7	19	~ 49	~ 133	~ 63	~ 266
8	40 in. lbs		(1-2)* 7	(1-2)* 19	~ 49	~ 133	(1-2)* ~ 41	(1-2)* ~ 168
10	35 in. lbs	1	(1-2)* 7	(1-2)* 19			(1-2)* ~ 27	(1-2)* ~ 104
12	35 in. lbs	1	(1-4)* 7	(1-4)* 19			(1-2)* ~ 19	(1-2)* ~ 65
14	35 in. lbs	1	(1-4)* 7	(1-4)* 19			(1-2)* ~ 19	(1-2)* ~ 41

~ Quantity of strands for Classes G, H, I, K may vary by manufacturer.

* Multiple conductor approvals for **LOAD** side only. (copper wire only)

Aluminum stranded wire ranges: 1/0 – 14, #2 – #14 AWG

- Wire strip length, line side tap – 1 9/16”
- Wire strip length, load side tap, top row – 1/2”, middle row – 11/16”, bottom row – 15/16”
- Hex keys required : line side - 1/2”, load side - 5/32” and 3/16”
- Panel mountable: #10 fastener, torque to 25-30 in. lbs

Accessories:

- Snap-on hinged covers: CH 133X (Replace “X” with 1, 2 or 3 for number of poles) UL recognized, glass filled polycarbonate (thermoplastic).125 °C (UL RTI), UL 94 V-0.
- Marker Strips. Printing available. Consult factory.

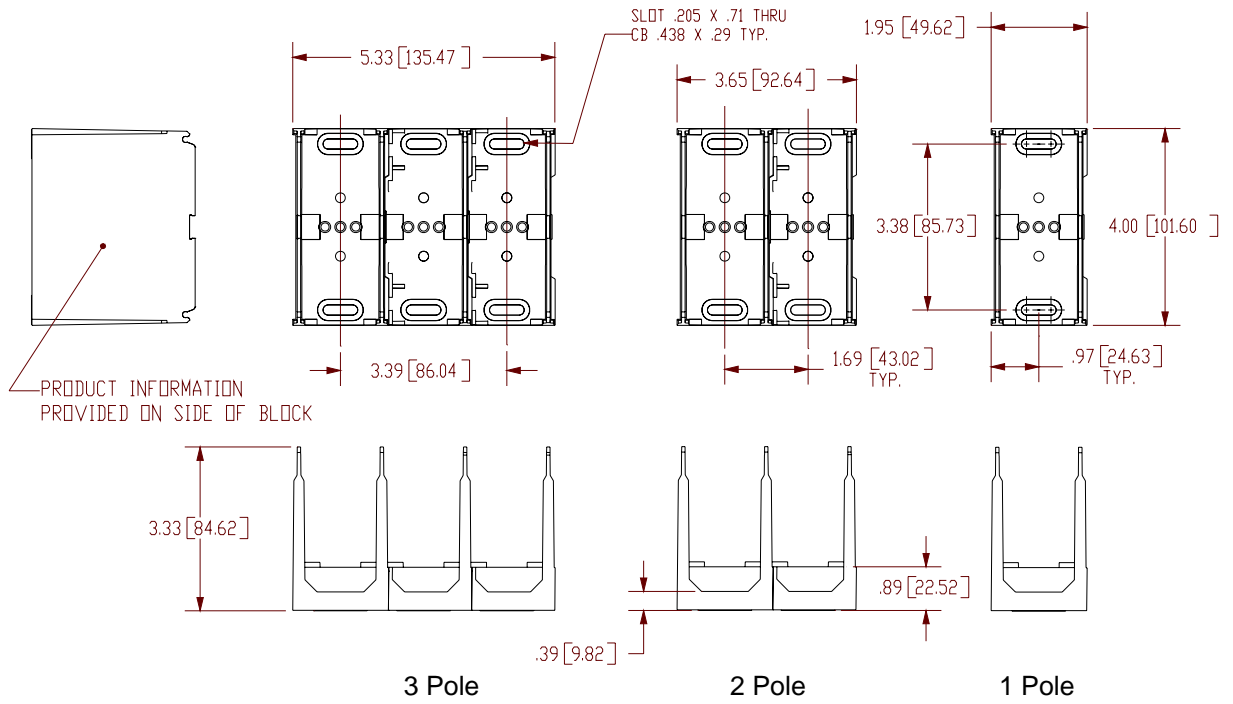

WWW.MARATHONSP.COM
 1-419-352-8441

PDS 0036 REV C 4/23/09