

Product Data Sheet



R6F30AXB

Replace "X" with 1, 2 or 3 for number of poles

Reinforced Class H Fuse Holder 30 Amps, 600 Volts AC

Wire Range:

Line side: (1) #6 - #14 AWG

Load Side: (1) #6 - #14 AWG



[See tables below for wire sizes.](#)

Holds fuse size 13/16" diameter X 5"

Commonly used fuses in this holder: A6Y, CRS, NLS, NOS, NRS, OTS, RES, RFS, RLS

Electrical Ratings:

- 0 - 30A max (amperage rating based on maximum fuse rating for that physical size)
- Copper wire only
- 600 Volts AC
- Approved for 10,000 Amp Withstand Rating

Mechanical Ratings:

- Maximum insulator base temperature: 150°C (302°F) UL RTI
- Storage and transportation temperature range: -35°C to 125°C (-31°F to 257°F)
- Flammability rating of insulator base: UL 94 V-0
- Touch protection: IP-20 (IEC 60529) with optional cover CHR630 (See accessories)
 - Use outside these ratings needs to be judged in the end-use application.

Materials:

- Fuse Clip: Copper alloy, tin plated
- Box Connector: High conductivity aluminum, Tin plated
- Reinforcing Spring: Steel, zinc plated
- Insulator base: phenolic
- Terminal set screws: Steel, tin plated
- Fuse Clip anchor screws: Steel, zinc plated

Agency Approvals:

- UL Listed, UL 512 Terminal Block Standard, File No. IZLT2.E35113
- CSA Certified, CSA C22.2 No. 39 – M1987, File No. LR21455
- CE compliant to IEC 60947-1
- RoHS Compliant

Wire Approvals:**Line and Load Side Wire Approvals:**

Wire Size	Torque	Copper Wire Stranding Classes - Number of Strands		
		Solid	Class B	Class C
6 AWG	25 in. lbs		7	19
8	25 in. lbs		7	19
10	25 in. lbs	1	7	19
12	25 in. lbs	1	7	19
14	25 in. lbs	1	7	19

- Wire strip length, line and load side wire taps – 7/16”
- Panel mountable: #1/4” (M6) fastener, torque to 30-40 in. lbs.

Accessories:

- Cover: CHR630. Glass-filled polycarbonate (thermoplastic). 125 °C (UL RTI), Flammability rating UL 94 V-0, UL Listed File No. JDVS2.181825.

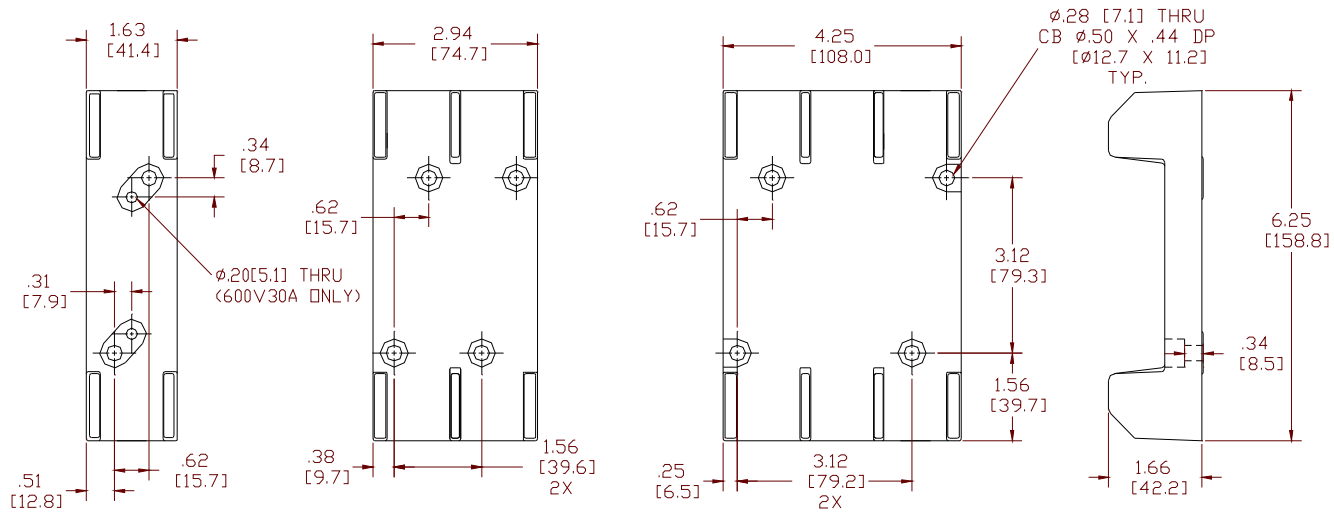

WWW.MARATHONSP.COM
1-419-352-8441

PDS 0148 REV A 10/02/07