

Product Data Sheet



ST750M8

Motor Terminal Block
 160 Amps, 1000 Volts UL (AC/DC)
 1000V CE, 1,100V SANS 1804



- Line and Load side: M8 stud
 Wire range: 2/0 - #12 AWG (70 -4 mm²) stranded Cu wire
 • Studs intended for use with listed crimp/compression lugs.

Electrical and Agency Ratings:

Agency				Amperage			Voltage							
UL 1059	CSA 22.2 #158	CE IEC 60947-7-1	SANS 1804-2	UL/CSA	CE		UL/CSA		CE			SANS		
XCFR2. E62806	XCFR8. E62806	XCHG2. E243117	XCHG2. E243117	Amp Rating	Amp Rating (I _{th})	Short Time Withstand Current (I _{cw})	Volt Rating	Use Group	Volt Rating (U _i)	Material Group	Pollution Degree	Volt Rating	Clearance Through air (min.)	Creepage Over Surface (min.)
				160	185	8,088	1000	E	1000	I	3	1100	0.63 (16.0)	0.85 (21.6)

Mechanical Ratings:

- Maximum insulator base temperature: 130°C (266°F) UL RTI
- Flammability rating of insulator base: UL 94 V-0
- * Use outside these ratings needs to be judged in the end-use application.

Materials:

- Link: Copper, nickel plated
- Insulator base: Thermoset polyester
- Threaded stud: Steel, nickel plated
- Hex nut: Steel, zinc plated
- Flat washer: Steel, zinc plated
- Lock washer: Steel, zinc plated
- RoHS Compliant
- REACH Compliant

Torque:

Line and Load Side Torque:

- Wire range: 2/0 - #12 AWG (70 – 4 mm²) Stranded Cu wire
- 106 in. lbs. (12.0 N·m)
- Hex nut: 13 mm across flats

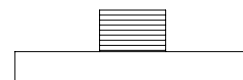

- Panel mountable: 5/16 (M8) fastener, torque to 40 – 50 in. lbs. (4.5 – 5.7 N·m)

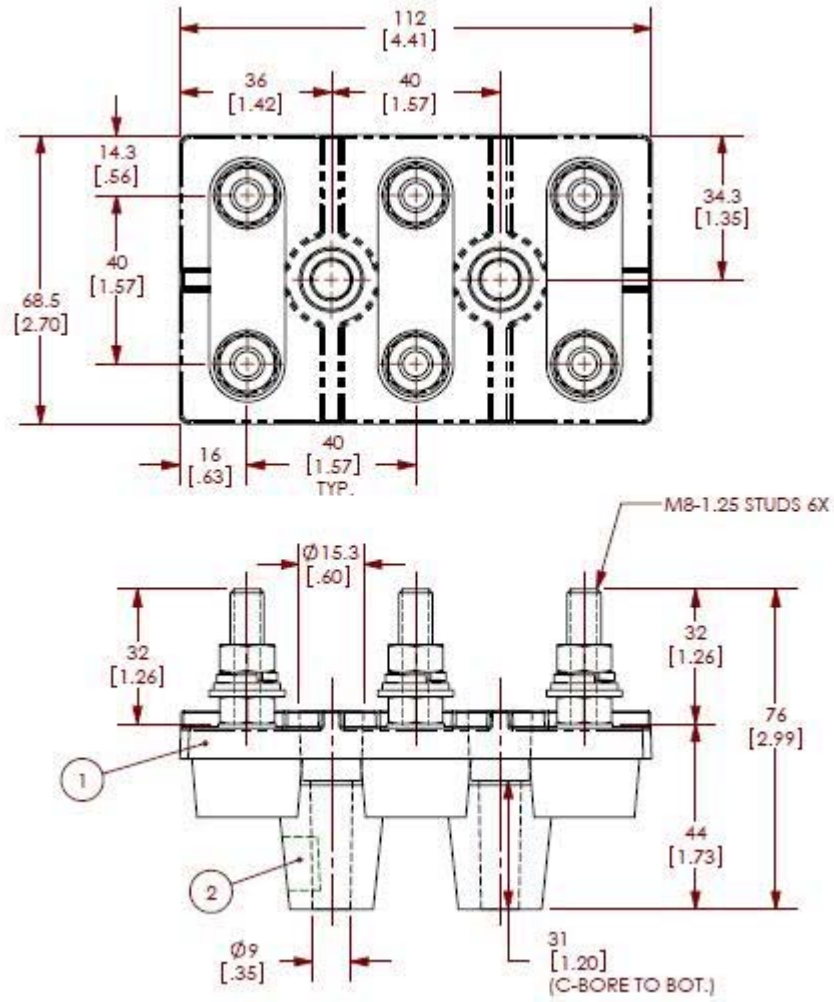

WWW.MARATHONSP.COM
1-419-352-8441